

Patch NATACHA FULL 2023/24

CH	Type	Mic	Insert	Stand
1	Kick	B 52	Comp/Gate Drawmer DS 201	
2	Snare top	B 57	C.L.DBX 160	small
3	Snare bot	SM 57, C535	Gate Drawmer DS 201	small
4	Hi Hat	C 451/ ksm 137		boom
5	Floor Tom	B 98	Comp/Gate Drawmer DS 201	
6	Mid Tom	B 98	Comp/Gate Drawmer DS 201	
7	High Tom	B 98	Comp/Gate Drawmer DS 201	
8	O.H.L	C 414, SM 81		boom
9	O.H.R	C 414, SM 81		boom
10	Bass DI	Di BSS AR 133	C.L.DBX 160	
11	eGuitr	e609 or SM57		small
12	eGuitr Amp2	e609 or SM57		small
13	Acc Guitr	Di BSS AR 133	comp	
14	Keys L	Di BSS AR 133		
15	Keys R	Di BSS AR 133		
16	Keys 2L	Di BSS AR 133		
17	Keys 2R	Di BSS AR 133		
18	Click	Radial (own)		
19	Loops	Radial (own)		
20	Comp L	Radial (own)		
21	Comp R	Radial (own)		
22	Backing L	Radial (own)		
23	Backing R	Radial (own)		boom
24	Bvox	SM 58	C.L.DBX 160	boom
*25	Vox Natacha	UHF 87/ SM58	* Avalon VT-737 (OWN)	OWN
26	BVox spare	SM 58		
27	FX1 PCM 70 L			
28	FX1 PCM 70 R			
29	FX2 M 3000 L			
30	FX2 M 3000 R			
31	FX3 TC D-Two L			
32	FX3 TC D-Two R			
33	CD L			
34	CD R			
35	iPod L			
36	iPod R			

37
38

* direct mic input before patching into the desk, the Avalon is placed at the FOH console. if digital desk, please make sure, there are enough insert points at FOH position

For more info please contact

Mobile : +41 79 422 58 18

E-Mail :daniel.platista@q-lab.ch

IF Yamaha digital console, we will send you an addapted PATCH-CONSOLE FILE
IF iLive console, we will send you an addapted PATCH-CONSOLE FILE
IF SC Vix console, we will send you an addapted PATCH-CONSOLE FILE

Technical Rider NATACHA

F.O.H :

digital console preferred (Yamaha M7, CL, A&H iLive, Venue, Soundcraft Vix)

analog console 48/8/8/2 (Midas XL-4, XL 3 Yamaha PM3500, PM4000 ,
RH Soundcraft Serie 5) - or minimum 32/8/8/2

please no Crest and Yamaha M2000, 2500, 3000 series

The system must deliver 100 DB at the FOH console position without any signal distortion. Natacha's sound engineer must have acces to all speaker managment systems , processors and/ or Eqs

Only needed if analog console:

8x Compressors, DBX 160 or BSS DPR 402-404

(not DBX 166A series or Behringer) ,

8x Gates, Drawmer DS-201 series

If no monitor console: the FOH console must have min 12-16 aux output

Monitor:

Console 32 with minimum 8 aux (Midas, Yamaha, Paragon II) ,

8 EQ insert in groupes (BSS, Aphex) ,

5 Wedges (UM-1, PS15, L-Acoustic) ,

1 Sub for Drumfill ,

2 Side Fill ,

4 Gate Drawmer DS 201 ,

1 Compressor Stereo ,

1 Reverb ,

1x Monitor PFL same type as on stage ,

PA:

Professional system adapted to the place and the number of spectators. ,

(Meyer sound M3D, M2D, MSL4, V-Dosc, NEXO GEO, Adamson, Turbosound)

Soundcheck:

The group needs 2h ,

For more info please contact

Mobile : +41.79.422.58.18 ,

E-Mail : daniel.platisa@q-lab.ch

Monitor Patch NATACHA

1 Drum	In-Ear mono XLR	XLR/Jack cable
2 Bass	2 wedges	
3 Keys	In-Ear mono XLR	XLR/Jack cable
4 eGuit	2 wedges	
5 Natacha	In-Ear mono (own)	XLR cable
6 Drum	Wedge/ Subwedge	
7 Backing Aux	2 wedges	
8 Reverb		
9 Delay		
10		

For more info please contact

Mobile : +41.79.422.58.18 ,
E-Mail :daniel.platisa@q-lab.ch

Stageplan Natacha

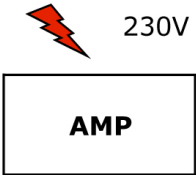
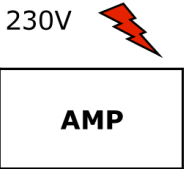
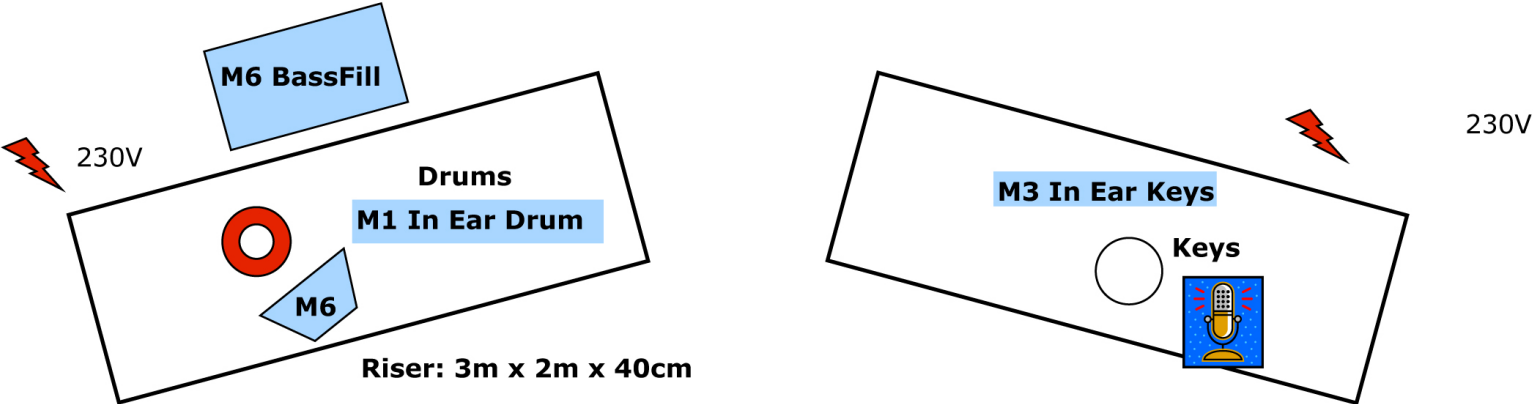

eGuit *eventuell Unplugged Roman)*

Bass

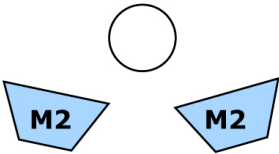

M5 In Ear Natacha